

Size 4 Vacuum Contactor



7.1 NEMA, Special Purpose and Mining Rating

Product Description	V5-T7-2
Application Description	V5-T7-2
Operation	V5-T7-2
Features	V5-T7-2
Benefits	V5-T7-2
Standards and Certifications	V5-T7-2
Product Selection	V5-T7-3
Accessories	V5-T7-4
Replacement Parts	V5-T7-6
Technical Data and Specifications	V5-T7-7
Wiring Diagrams	V5-T7-9
Dimensions	V5-T7-10

NEMA, Special Purpose and Mining Rating



7

Contents

<i>Description</i>	<i>Page</i>
NEMA, Special Purpose and Mining Rating	
Product Selection	V5-T7-3
Accessories	V5-T7-4
Replacement Parts	V5-T7-6
Technical Data and Specifications	V5-T7-7
Wiring Diagrams	V5-T7-9
Dimensions	V5-T7-10

Product Description

Vacuum contactors and starters were designed for starting and controlling three-phase, 50/60 Hz, AC motors. Each contact is enclosed in a vacuum bottle to reduce and contain contact arcing. This design offers excellent performance for plugging and jogging applications.

Application Description

The vacuum contactors and starters are offered in three classifications. They are NEMA® rated devices up to 600 Vac, Special Purpose rated devices up to 1500 Vac and Mining rated devices rated up to 1500 Vac. Each device is tested to different standards to serve its market.

Typical applications include full voltage control of three-phase squirrel cage motors, primary control of low voltage wound rotor motors and circuit switching for low voltage capacitors for power factor improvement.

A vacuum contactor is affected by atmospheric pressure on the bellows of the vacuum bottles. Up to an altitude of 6600 feet, the contactor is designed to tolerate normal variations in barometric pressure. If the contactor is to be operated above 6600 feet above sea level, consult your Eaton representative.

Operation

The contact structure of the vacuum break contactor is located inside sealed ceramic tubes that have been evacuated of air. Any arc occurring across the contacts upon opening is automatically extinguished because ionized air is not available to sustain it—the arc breaks when the current passes through zero. The arc typically does not service beyond the first half cycle once the contacts begin to separate. The large arc chutes normally associated with contactors of this size are not required. The ceramic tube with the moving and stationary contacts is called a **vacuum interrupter or bottle**. There is one bottle for each pole on the contactor. A metal bellows (like a small, circular accordion) within the bottle allows the moving contact to be closed and pulled open from the outside without leaking air into the bottle. Both the bellow and the metal-to-ceramic seals of these state-of-the-art bottles have been refined to the point where the possibility of loss of vacuum has been virtually eliminated.

Features

- Rugged, compact and lightweight
- Quiet operation
- Electrical and mechanical interlocks available
- Long service life

Benefits

- Easy maintenance with front removable coil and auxiliaries
- Eliminate extra surge suppressors with the standard low chop interrupters
- Plan your preventative maintenance schedule by utilizing the contact wear indicator, standard on all vacuum bottles

Standards and Certifications

- NEMA Devices
 - UL® Listed File #E1491, Guide Number NLDX
 - CSA® Approved
- Special Purpose Devices
 - IEC 947-4-1
 - UL Listed File #E1491, Guide Number NLDX
 - CSA Approved



Product Selection

When Ordering Specify

- Catalog number
- Heater pack if ordering a starter, order in quantities of three
- Any required accessories

Size 4 Vacuum Contactor



NEMA Rated Vacuum Contactors and Starters

NEMA Size	Ampere Rating	Motor Voltage	Maximum Horsepower Rating	Magnet Coil Voltage ①	Contactors Non-Reversing Catalog Number	Contactors Reversing Catalog Number	Starters Non-Reversing Catalog Number ②
4	135	200	40	110/120	V201K4CJ	V211K4CJ	V200M4CJC
		230	50	220/240	V201K4CK	V211K4CK	V200M4CK
		380	75	440/480	V201K4CU	V211K4CU	V200M4CU
		460	100				
575	100						
5	270	200	75	110/120	V201K5CJZ1	V211K5CJZ1	V200M5CJC
		230	100	220/240	V201K5CKZ1	V211K5CKZ1	V200M5CK
		380	150	440/480	V201K5CUZ1	V211K5CUZ1	V200M5CU
		460	200				
		575	200				
6	540	200	150	110/120	V201K6CJZ1	V211K6CJZ1	V200M6CJC
		230	200	220/240	V201K6CKZ1	V211K6CKZ1	V200M6CK
		380	300	440/480	V201K6CUZ1	—	V200M6CU
		460	400				
		575	400				

160 A Vacuum Contactor



Special Purpose Vacuum Contactors and Starters

Ampere Rating	Motor Voltage	Maximum Horsepower Rating	Magnet Coil Voltage ①	Contactors Non-Reversing Catalog Number	Contactors Reversing Catalog Number	Starters Non-Reversing Catalog Number ②	Starters Reversing Catalog Number ②
160	200	50	110/120	V201KRCJ	V211KRCJ	—	—
	230	60	220/240	V201KRCK	V211KRCK	—	—
	380	100	380/415	V201KRCH	V211KRCH	—	—
	460	125					
	575	150	440/480	V201KRCU	V211KRCU	—	—
	800	200					
	1000	250					
1500	400						
320	200	100	110/120	V201KTCJZ1	V211KTCJZ1	V200MTCJC	V210MTCJC
	230	125	220/240	V201KTCKZ1	V211KTCKZ1	V200MTCK	V210MTCK
	380	200	380/415	V201KTCHZ1	V211KTCHZ1	V200MTCH	V210MTCH
	460	250					
	575	300	440/480	V201KTCUZ1	V211KTCUZ1	V200MTCU	V210MTCU
	800	450					
	1000	500					
1500	900						
540	200	150	110/120	V201KVCJZ1	V211KVCJZ1	V200MVCJ	V210MVCJ
	230	200	220/240	V201KVCKZ1	V211KVCKZ1	V200MVCK	V210MVCK
	380	300	380/415	V201KVCHZ1	—	V200MVCH	—
	460	400					
	575	500	440/480	V201KVCUZ1	—	V200MVCU	—
	1000	1000					
1500	1250						
610	200	200	110/120	V201KZCJZ1	V211KZCJZ1	—	—
	230	200	220/240	V201KZCKZ1	V211KZCKZ1	—	—
	380	300	380/415	V201KZCHZ1	—	—	—
	460	450					
	575	500	440/480	V201KZCUZ1	—	—	—
	800	800					
	1000	1000					
1500	1600						

Notes

- ① Coils are rated for 50/60 Hz applications.
- ② Starters use Type B overload relay. Refer to Heater Coil Selection table on **Page V5-T7-6**. Starters do not include heater packs.

7.1

Vacuum Contactors and Starters

NEMA, Special Purpose and Mining Rating

160 A Mining Vacuum Contactor



Mining Rated Vacuum Contactors and Starters

Ampere Rating	Motor Voltage	Maximum Horsepower Rating	Magnet Coil Voltage ①	Contactors Non-Reversing Catalog Number
160	200	50	110/120	VM160CJ
	230	60	220/240	VM160CK
	380	100		
	460	125	440/480	VM160CU
	575	150		
	800	200		
320	1500	400		
	200	100	110/120	VM320CJZ1
	230	125	220/240	VM320CKZ1
	380	200		
	460	250	440/480	VM320CUZ1
	575	300		
800	450			
610	1500	900		
	200	150	110/120	VM610CJZ1
	230	200	220/240	VM610CKZ1
	380	300		
	460	400	440/480	VM610CUZ1
	575	500		
800	800			
	1500	1600		

Accessories

Lug Sizes

- Size 4—12–4/0
- NEMA Size 5 and 6 and 320 A, 540 A and 610 A—supplied without line or load lugs.

Lug Kits—Consist of Six Lugs

Size	Description	Catalog Number
5 and 320 A	1/0–500 kcmil	C325KAL8
6, 540 A and 610 A	1/0–500 kcmil double barrel	C325KAL9
610 A	1/0–600 kcmil double barrel	80-19825-2

Field Modification Kits

Auxiliary Electrical Contacts

Size 4—Three Type J auxiliary contacts may be mounted on the top of Size 4 contactors to provide six auxiliary, isolated 600 V, 10 A contacts for use in control circuits.

Sizes 5–6—Two Type J auxiliary contacts may be mounted on each side of Size 5 and 6 contactors to provide four auxiliary, isolated 600 V, 10 A contacts for use in control circuits.

Auxiliary Electrical Contacts

Contact Arrangement	Catalog Number
1NO, 1NC	J11
1NO, 1NC CC ②	J1CV
2NO	J20
2NC	J02

Horizontal Mechanical Interlock

Size	Catalog Number
4	180C113G04
5	180C113G16
5	180C113G17

Notes

- ① Coils are rated for 50/60 Hz applications.
- ② Used with Size 4 only. CC is coil clearing.

AEGIS Powerline Filters



Ideal for applications that utilize 120 Vac or 240 Vac control voltage and have the likelihood of harmonics or noise being present on the control signal. These are stand-alone devices, not mounted to the contactor.

AEGIS Powerline Filters Protect Against the Full Spectrum of Transient Disturbances

AEGIS filters the entire sine wave and is effective against both frequently occurring low energy and occasional high energy transients. High energy transients can create immediate damage, while low energy transients cause coil failure over time.

Catalog Numbering System

AEGIS-HW (Hard Wire Application)

230 V applies to 220 V and 240 V applications.

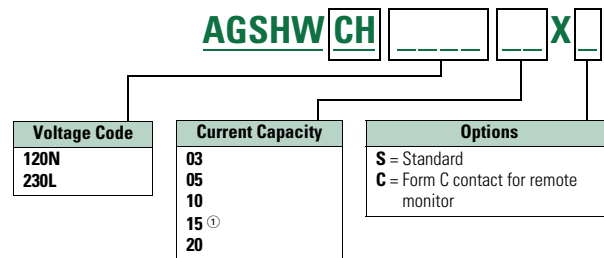

AEGIS Powerline Filters

Catalog Number ^②	Catalog Number ^②
AGSHWCH120N03XC	AGSHWCH230L03XC
AGSHWCH120N03XS	AGSHWCH230L03XS
AGSHWCH120N05XC	AGSHWCH230L05XC
AGSHWCH120N05XS	AGSHWCH230L05XS

Notes

- ^① Model tested at 15 A UL/CSA = 16 A CE.
- ^② See AEGIS Powerline Filters in **Volume 3—Power Distribution and Control Assemblies**, CA08100004E, Tab 2.

7.1

Vacuum Contactors and Starters

NEMA, Special Purpose and Mining Rating

Heater Coils

Heater Coils for Type B Overload Relay ^①

Open Starter Ambient Compensated Overload Relay	Heater Catalog Number ^②	Open Starter Ambient Compensated Overload Relay	Heater Catalog Number ^②
Size 4 and 160 A		Size 5 and 320 A with 300/5 Current Transformers	
12.8–14.1	FH68	107–117	FH23
14.2–15.5	FH69	118–129	FH24
15.6–17.1	FH70	130–141	FH25
17.2–18.9	FH71	142–155	FH26
19.0–20.8	FH72	156–170	FH27
20.9–22.9	FH73	171–187	FH28
23.0–25.2	FH74	188–205	FH29
25.3–27.8	FH75	206–224	FH30
27.9–30.6	FH76	225–244	FH31
30.7–33.5	FH77	245–263	FH32
33.6–37.5	FH78	264–292	FH33
37.6–41.5	FH79	293–318	FH34
41.6–46.3	FH80	319–350	FH35
46.4–50	FH81	Size 6 and 540 A with 600/5 Current Transformers	
51–55	FH82	236–259	FH24
56–61	FH83	260–283	FH25
62–66	FH84	284–310	FH26
67–73	FH85	311–340	FH27
74–78	FH86	341–374	FH28
79–84	FH87	375–411	FH29
85–92	FH88	412–448	FH30
93–101	FH89	449–489	FH31
102–110	FH90	490–527	FH32
111–122	FH91	528–585	FH33
123–129	FH92	586–600	FH34
130–133	FH93		
—	FH94		

Replacement Parts

Vacuum Contactor—Replacement Coils

Description	Suffix	Part Number
Size 4		
110/120 Vac, 50/60 Hz	J	9085A57G01
220/240 Vac, 50/60 Hz	K	9085A57G02
380/415 Vac, 50/60 Hz	H	ID89221G07
440/480 Vac, 50/60 Hz	U	9085A57G03
Size 5		
110/120 Vac, 50/60 Hz	J	7874A09G01 ^③
220/240 Vac, 50/60 Hz	K	7874A09G04 ^④
380/415 Vac, 50/60 Hz	H	7874A09G10
440/480 Vac, 50/60 Hz	U	7874A09G05
Size 6		
110/120 Vac, 50/60 Hz	J	7874A24G01 ^③
220/240 Vac, 50/60 Hz	K	7874A24G02 ^④
380/415 Vac, 50/60 Hz	H	7874A24G07
440/480 Vac, 50/60 Hz	U	7874A24G03

Notes

- ① Motor full load current in amperes for use with three heaters only.
- ② Three are required per overload relay.
- ③ 125 Vdc can be directly applied to the Size 5 and 6 coil rated for 120 Vac/60 Hz (cannot be applied to Size 4).
- ④ 250 Vdc can be directly applied to the Size 5 and 6 coil rated for 240 Vac/60 Hz (cannot be applied to Size 4).

Technical Data and Specifications

NEMA, Special Purpose and Mining Rating

Description	NEMA			Special Purpose			
	Size 4 V201K4_	Size 5 V201K5_	Size 6 V201K6_	160 A V201KR_	320 A V201KT_	540 A V201KV_	610 A V201KZ_
Poles	3	3	3	3	3	3	3
Maximum voltage rating	600 V	600 V	600 V	1500 V	1500 V	1500 V	1500 V
Ampere rating	135 A	270 A	540 A	160 A	320 A	540 A	610 A
Frequency, Hz	50/60	50/60	50/60	50/60	50/60	50/60	50/60
Maximum closing current	1600 A	3000 A	6000 A	1600 A	3000 A	6000 A	6000 A
Maximum interrupting current	1600 A	3000 A	6000 A	1600 A	3000 A	6000 A	6000 A
Short time current							
1 second	2400 A rms	4500 A rms	9000 A rms	2400 A rms	4500 A rms	9000 A rms	9000 A rms
2 second	1600 A rms	3000 A rms	6000 A rms	1600 A rms	3000 A rms	6000 A rms	6000 A rms
Dielectric strength	2200 Vac	5375 Vac	5375 Vac	2200 Vac	5375 Vac	5375 Vac	5375 Vac
Maximum allowable interrupting	1200/hr	—	—	1200/hr	—	—	—
Impulse voltage (1 x 40 ms)	15 kV	15 kV	15 kV	15 kV	15 kV	15 kV	15 kV
Maximum motor hp at:							
200 V	40 hp	75 hp	150 hp	50 hp	100 hp	150 hp	200 hp
230 V	50 hp	100 hp	200 hp	60 hp	125 hp	200 hp	200 hp
380 V	75 hp	150 hp	300 hp	100 hp	200 hp	300 hp	300 hp
460 V	100 hp	200 hp	400 hp	125 hp	250 hp	400 hp	450 hp
575 V	100 hp	200 hp	400 hp	150 hp	300 hp	500 hp	500 hp
800 V	—	—	—	200 hp	450 hp	—	800 hp
1000 V	—	—	—	250 hp	500 hp	1000 hp	1000 hp
1500 V	—	—	—	400 hp	900 hp	1250 hp	1600 hp
Three-phase capacitive switching (kVAR):							
230 V	0 kvar	80 kvar	160 kvar	50 kvar	80 kvar	160 kvar	176 kvar
460 V	80 kvar	160 kvar	320 kvar	100 kvar	160 kvar	320 kvar	356 kvar
600 V	100 kvar	200 kvar	400 kvar	125 kvar	200 kvar	400 kvar	400 kvar
1500 V	—	—	—	205 kvar	500 kvar	—	1000 kvar
Transformer switching (kVA) [Ⓢ] single-phase, two-pole:							
120 V	6.8 kVA	14 kVA	27 kVA	8 kVA	14 kVA	27 kVA	27 kVA
240 V	14 kVA	27 kVA	54 kVA	16 kVA	27 kVA	54 kVA	54 kVA
480 V	27 kVA	54 kVA	108 kVA	32 kVA	54 kVA	108 kVA	108 kVA
600 V	34 kVA	68 kVA	135 kVA	40 kVA	68 kVA	135 kVA	135 kVA
Three-phase, three-pole:							
240 V	23 kVA	47 kVA	94 kVA	27 kVA	47 kVA	94 kVA	94 kVA
480 V	47 kVA	94 kVA	188 kVA	55 kVA	94 kVA	188 kVA	188 kVA
600 V	59 kVA	117 kVA	234 kVA	70 kVA	117 kVA	234 kVA	234 kVA

Note

[Ⓢ] For transformers having inrush currents of not more than 20 times the rated full load current.

7.1

Vacuum Contactors and Starters

NEMA, Special Purpose and Mining Rating

Electrical Characteristics—NEMA and Special Purpose Types

Description	Size		
	4 (160 A)	5 (320 A)	6 (540 A and 610 A)
DC coil data—burden: (AC supply rectified)			
Open VA	300 VA	500 VA	1450 VA
Closed VA	30 VA	25 VA	32 VA
Closed watts	6 W	20 W	30 W
Pick-up volts	70% of rated coil volts	70% of rated coil volts	70% of rated coil volts
Drop-out volts	50% of rated coil volts	50% of rated coil volts	50% of rated coil volts
Pick-up time in Hz	1.5–2 Hz	1.5–2 Hz	1.5–2 Hz
Drop-out time in Hz	6–6.15 Hz	6–6.15 Hz	6–6.15 Hz
Maximum voltage rating	600 V	600 V	600 V
Maximum closing current	1600 A	3000 A	6000 A
Maximum interrupting current	1600 A	3000 A	6000 A
Short time current:			
1 second	2400 A rms	4500 A rms	9000 A rms
2 second	1600 A rms	3000 A rms	6000 A rms

Electrical Characteristics Coil Data (AC Supply Rectified)

Burden	Size		
	4 (160 A)	5 (320 A)	6 (540 A and 610 A)
Inrush VA	300	600	1700
Sealed VA	30	20	28
Sealed watts	6	20	28
Pick-up volts	70% of rated coil volts	70% of rated coil volts	70% of rated coil volts
Drop-out volts	50% of rated coil volts	50% of rated coil volts	50% of rated coil volts
Pick-up time in Hz	1.5–2	1.5–2	1.5–2
Drop-out time in Hz	6–7.5	6–6.15	6–6.15

7

Wiring Diagrams

Size 4 Contactor

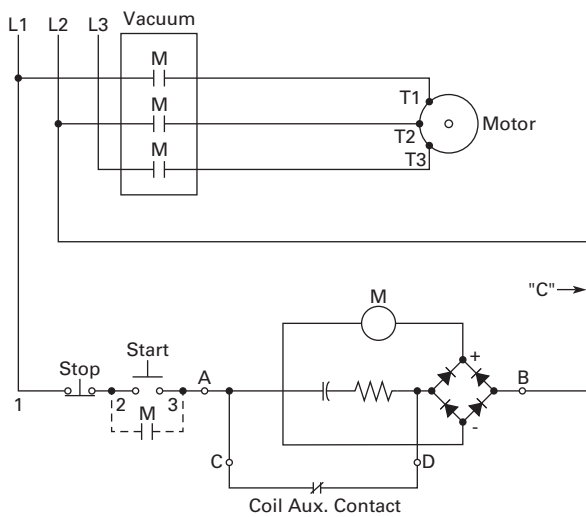

Sizes 5 and 6 Starter

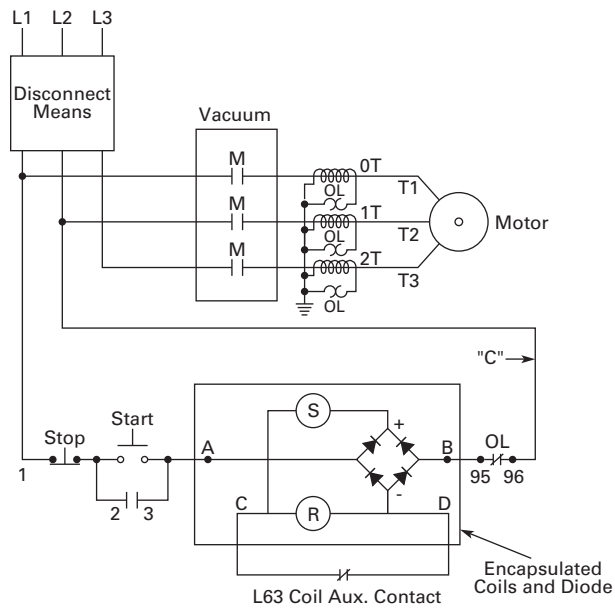

7.1

Vacuum Contactors and Starters

NEMA, Special Purpose and Mining Rating

Dimensions

Approximate Dimensions in Inches (mm)

Open Type Contactors and Starters—Size 4 and 160 A

Size and 160 A Non-Reversing Contactor

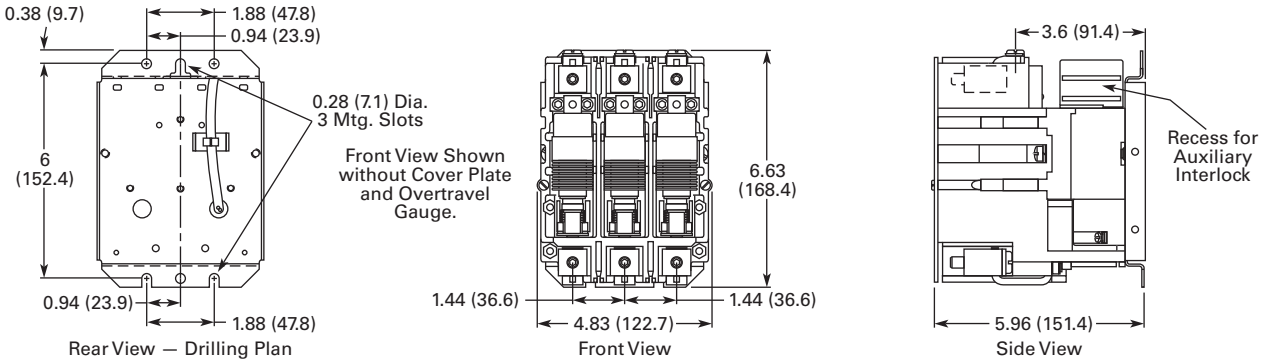

Size 4 and 160 A Reversing Contactor

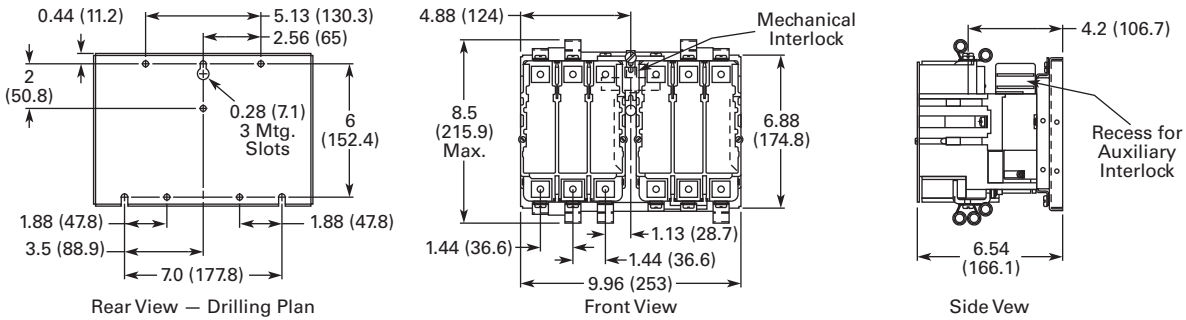

Size 4 Non-Reversing Starter

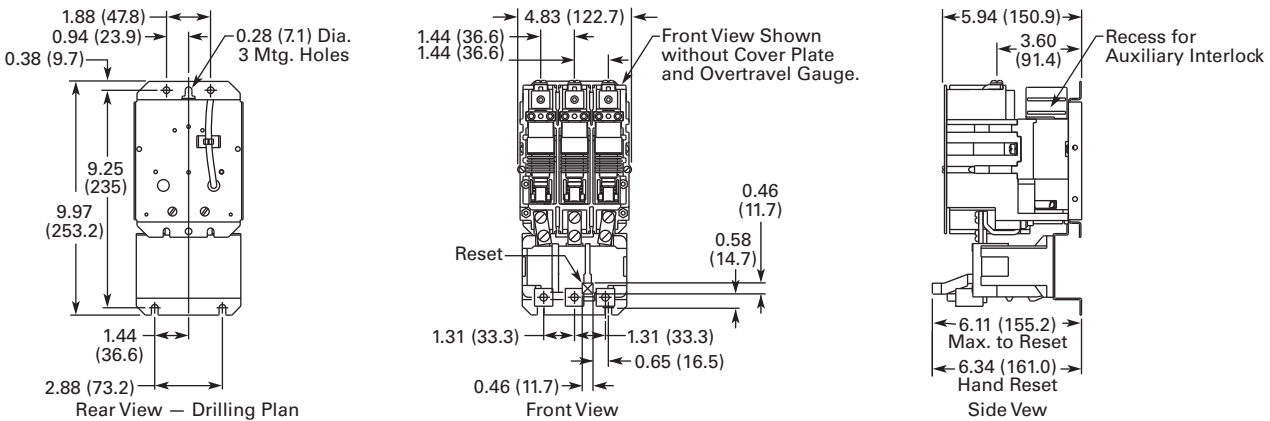

Approximate Dimensions in Inches (mm)

Open Type Contactors and Starters—Size 4 and 160 A, continued

Size 4 Reversing Starter

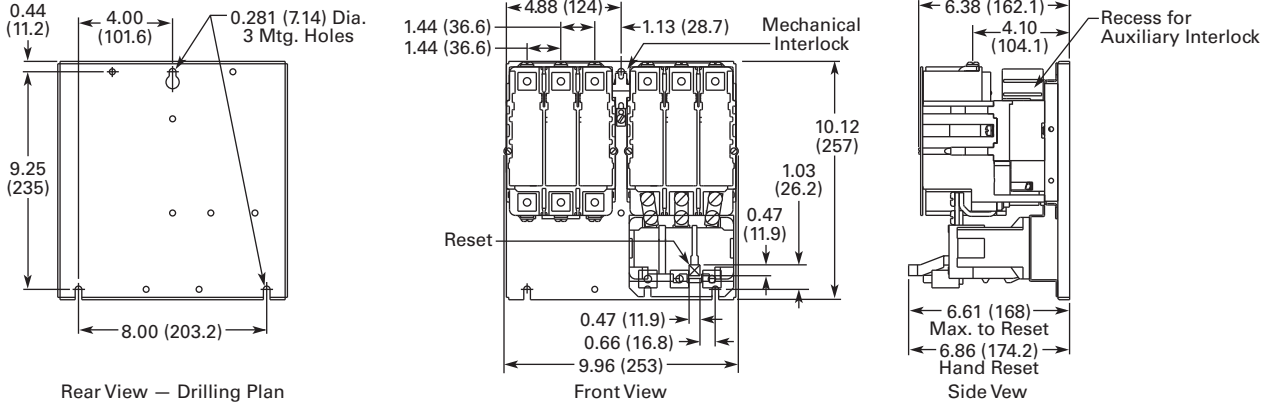

Open Type Contactors and Starters—Size 5 and 320 A

Size 5 and 320 A Non-Reversing Contactor

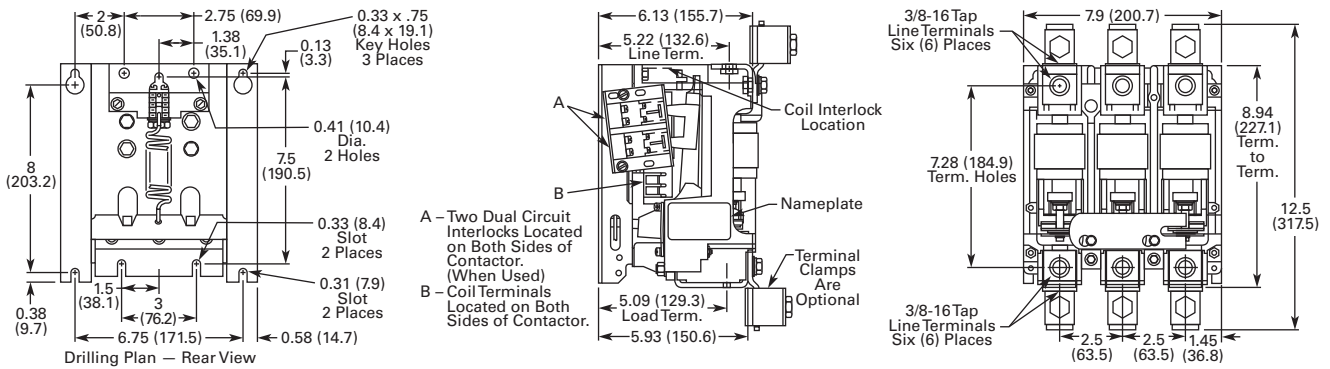

Size 5 and 320 A Reversing Contactor

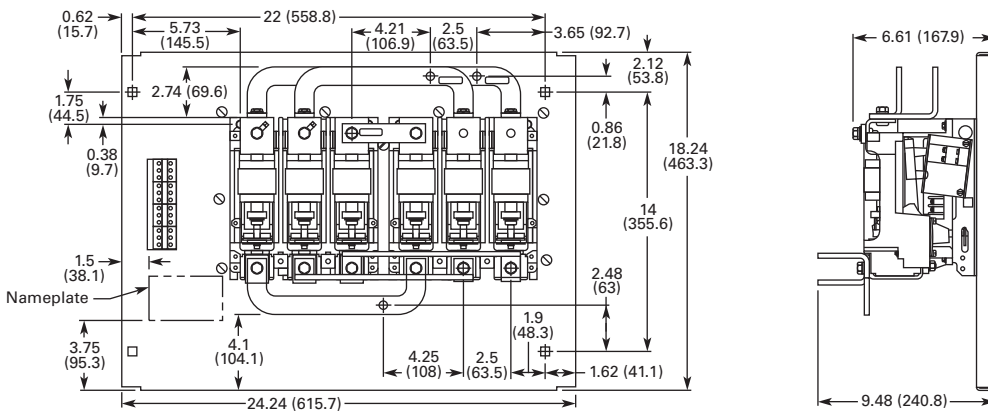

7.1

Vacuum Contactors and Starters

NEMA, Special Purpose and Mining Rating

Approximate Dimensions in Inches (mm)

Open Type Contactors and Starters—Size 5 and 320 A, continued

Size 5 and 320 Non-Reversing Starter

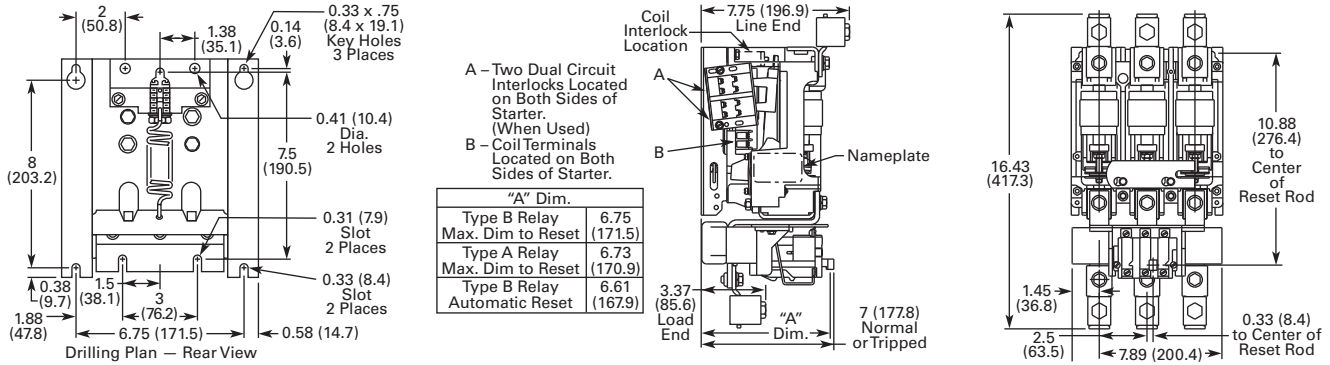

320 Reversing Starter

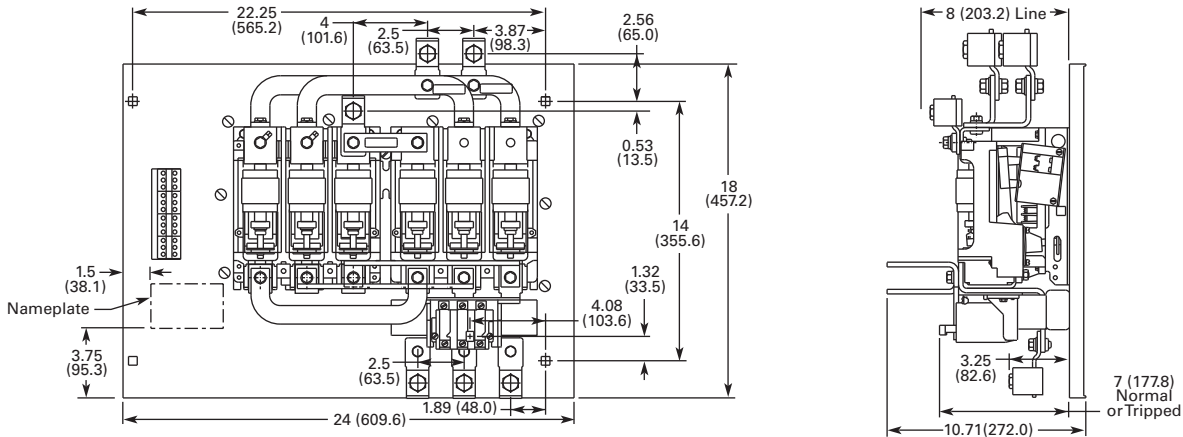

Approximate Dimensions in Inches (mm)

Open Type Contactors and Starters—Size 6, 540 A and 610 A

Size 6, 540 A and 610 A Non-Reversing Contactor

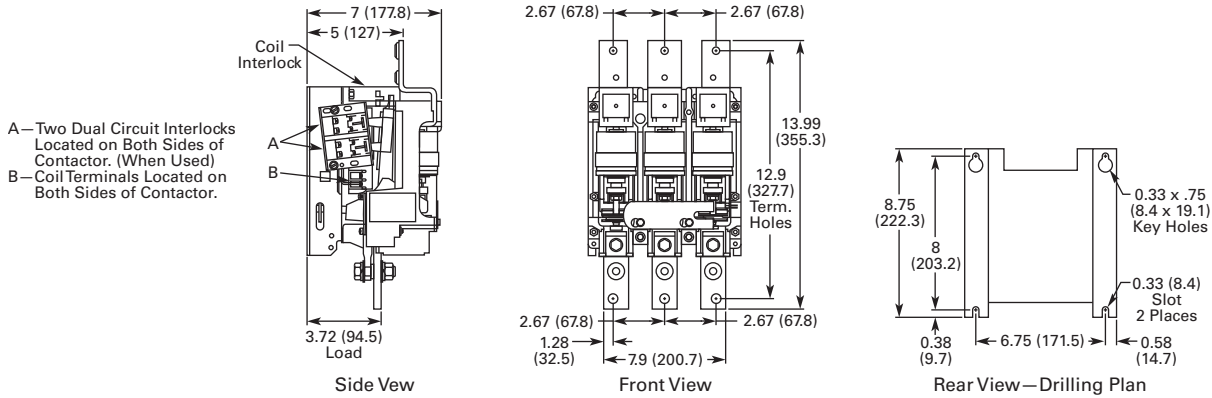

Size 6, 540 A and 610 A Reversing Contactor

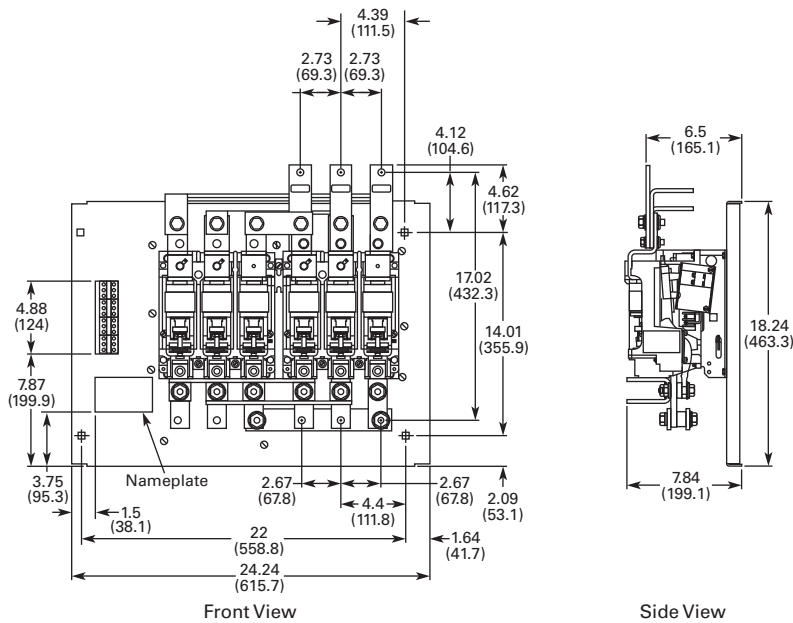

7.1

Vacuum Contactors and Starters

NEMA, Special Purpose and Mining Rating

Approximate Dimensions in Inches (mm)

Open Type Contactors and Starters—Size 6, 540 A and 610 A, continued

Size 6 and 540 A Non-Reversing Starter

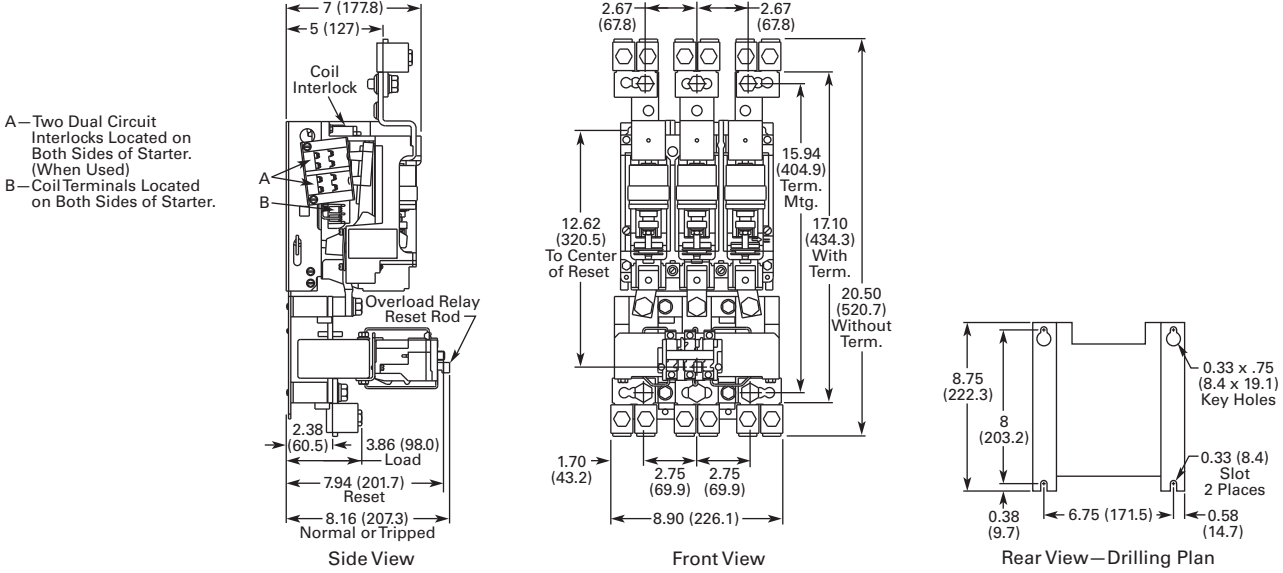

540 A Reversing Starter

